



Designed specifically for monitoring smoke opacity emissions within the marine industry

- **In situ measurement of smoke opacity directly in exhaust gas flow**
- **Measurement reading as % Opacity, smoke density as mg/m³ or Ringelmann**
- **Modulated LED source for long lifetime and immunity to ambient light**
- **Rugged 316L stainless steel construction**
- **Panel mounting Operator Interface enabling local monitoring and control of the instrument**
- **Choice of interface options enabling easy integration into ship's control system**

The SM-202M Smoke Opacity Monitor is an optical instrument designed to measure the visible opacity (0-100%) caused by dust, smoke and particulate emissions present in the exhaust gas flow of a duct, stack, or flue.

The SM-202M uses the standard single pass transmission measurement technique, with Transmitter/Receiver arrangement. A light beam emitted from the Transmitter passes across the stack to a Receiver, which measures the intensity of the received light. Increased particulate or smoke density in the stack gas attenuates the transmitted light and causes the intensity of the received light to fall. This reduction in intensity is measured and presented as % opacity. The higher the level of smoke present, the more light lost and therefore, the greater the opacity.

The light source in the Transmitter is a high intensity, high reliability red LED which provides long life and stable intensity. The transmitted light beam is pulsed to give complete immunity to ambient light levels. The intensity of the transmitted light is monitored at source so that any variations in the emitted light level are compensated for at the Receiver.

The unit is supplied with a panel mountable Operator Interface (OI) and all power supply and output connections are made in the OI. The OI has a bright 4 digit LED display and a simple 4 button keypad, which allow full command and control of the instrument.

The SM-202M is of rugged design and has an excellent reliability record. With no moving parts, regular maintenance simply involves cleaning the TX and RX lenses, which are easily accessible due to our latched head design. Both the TX and RX are supplied with an air purge body, which when connected to a high volume source of clean air, (a blower is recommended), will resist particle deposition on the lenses and further lengthen service intervals.

Specification:

Measurement Performance

No.	Parameter	Units	Min	Max	Comment
1	Path Length (flange to flange)	m	0.5	5	Flange-to-flange separation
2	Measurement Range				The displayed units and measurement range can be user selected to suit requirements Other measurement units also available
	Transmission		0	1.000	
	Opacity	%	0	100	
	Smoke Density	mg/m ³	0	1000	
3	Display Resolution				
	Transmission			0.001	
	Opacity	%		0.1	
	Smoke Density	mg/m ³		0.1	
4	Accuracy	Opacity	%	-2	+2
5	Damping	s	1	999	Default setting is 10s
6	Drift with Temperature	%	-2	+2	Over operating range
7	Operating Wavelength	nm	620	640	Red LED

Power & Air Requirements

8	Voltage	Vac	105	240	50/60 Hz
9	Nominal Current Consumption	A		1.0	
10	Power Up Current Consumption	A		1.0	
11	Air Supply Volume Flow	L/min	50	200	To each air-purge body.
12	Air Supply Fitting				1" BSP threaded aperture in each air-purge body

Cable and Wire

14	Cable type – TX/RX Interconnection	cores	6		Screened multi-core, such as Belden 9873
15	Cable type – OI/RX Interconnection	cores	4		Screened multi-core, such as Belden 9873
16	Wire Size at Terminal Connections	AWG	20	14	

Interface Options

17	Serial Comms				RS232 to the OI
18	Analogue Output (one)	Current	mA	4	20
		Voltage	V	0	10
19	Digital Relay Contacts (two)	A	0	3	@30Vdc (signal level and data valid)

Physical

20	Ingress Protection: - TX/RX Heads		IP65		For external use
21	Ingress Protection: - OI Panel Mounted		IP64		From front face of panel when installed
22	Ambient Operating Temperature	°C	-20	+55	Air temperature around the heads.
23	Operating Humidity	%		100	Air humidity around the heads.
24	Gas Temperature	°C	>dew point temp.	+600	Heat insulating gaskets included. (Higher temperatures on request)
25	Regulatory Compliance				2014/30/EU (Electromagnetic Radiation) 2014/35/EU (Low Voltage)
26	Materials:	- TX/RX Heads - Air-Purge Bodies - OI	AISI/SAE 316L stainless steel Powder coated cast aluminium (Stainless steel option available) Steel back-box; aluminium front panel with PU laminate overlay		
29	Weight:	- TX/RX Heads		2.5	Including air purge body
		- OI	kg	1.1	
31	Warranty	months	24		Return to base warranty. Extensions available

Configuration:

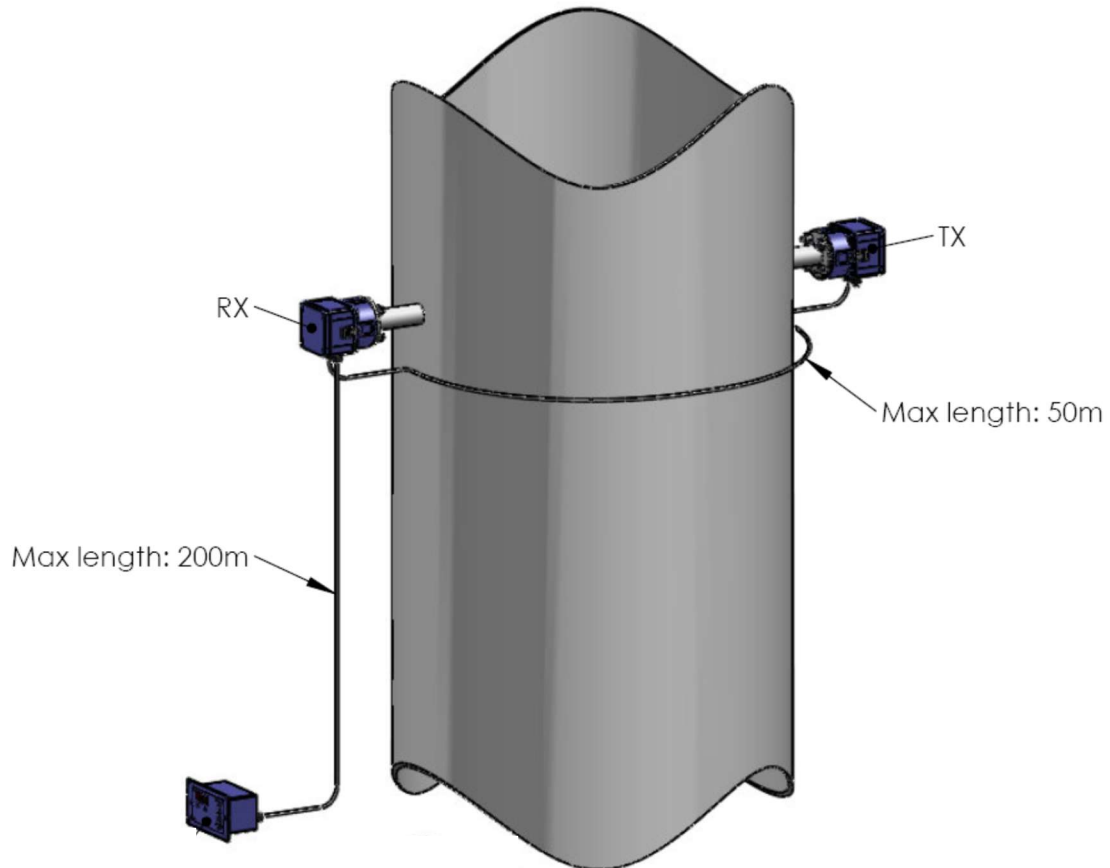

OI Dimensions (mm):

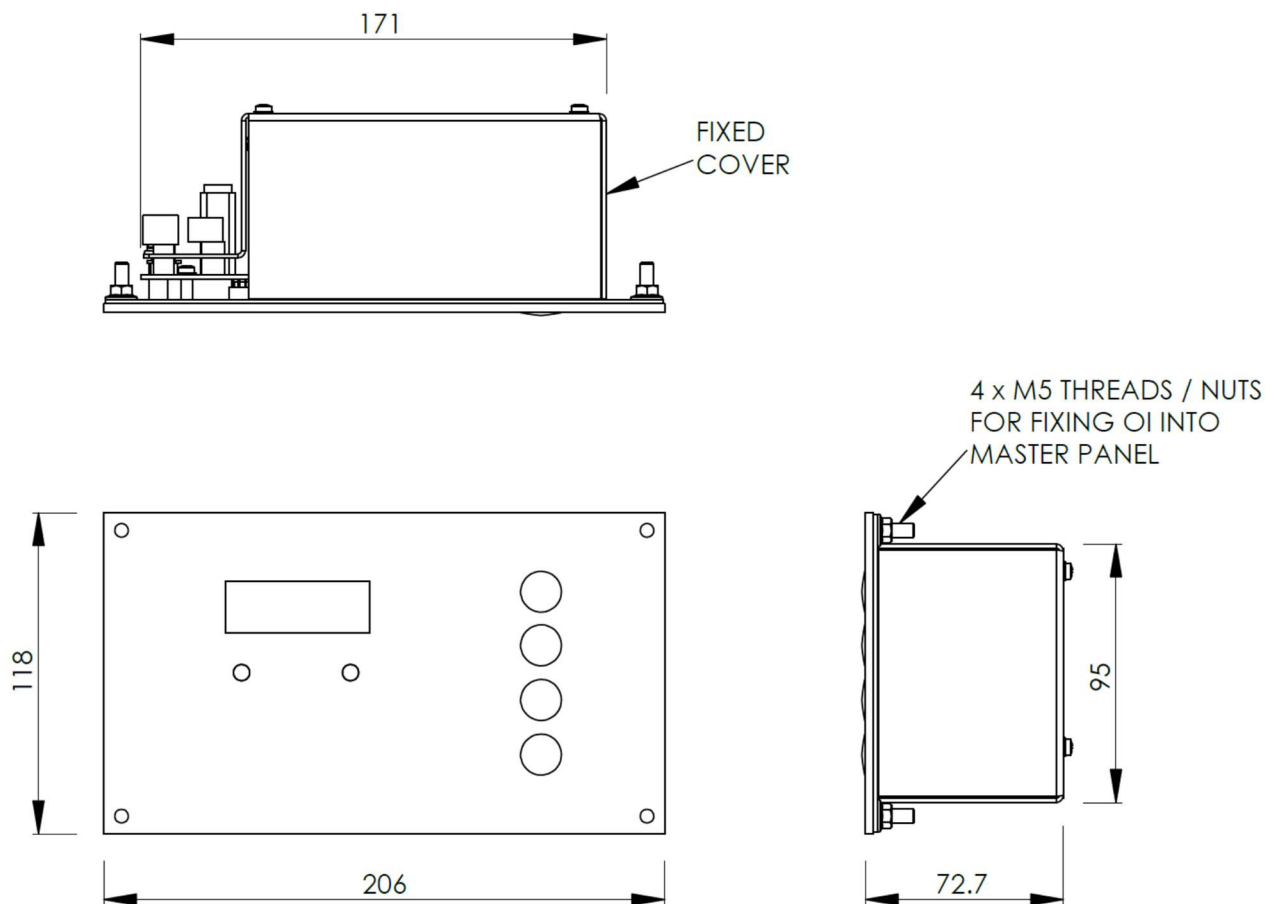

TX / RX Dimensions (mm):

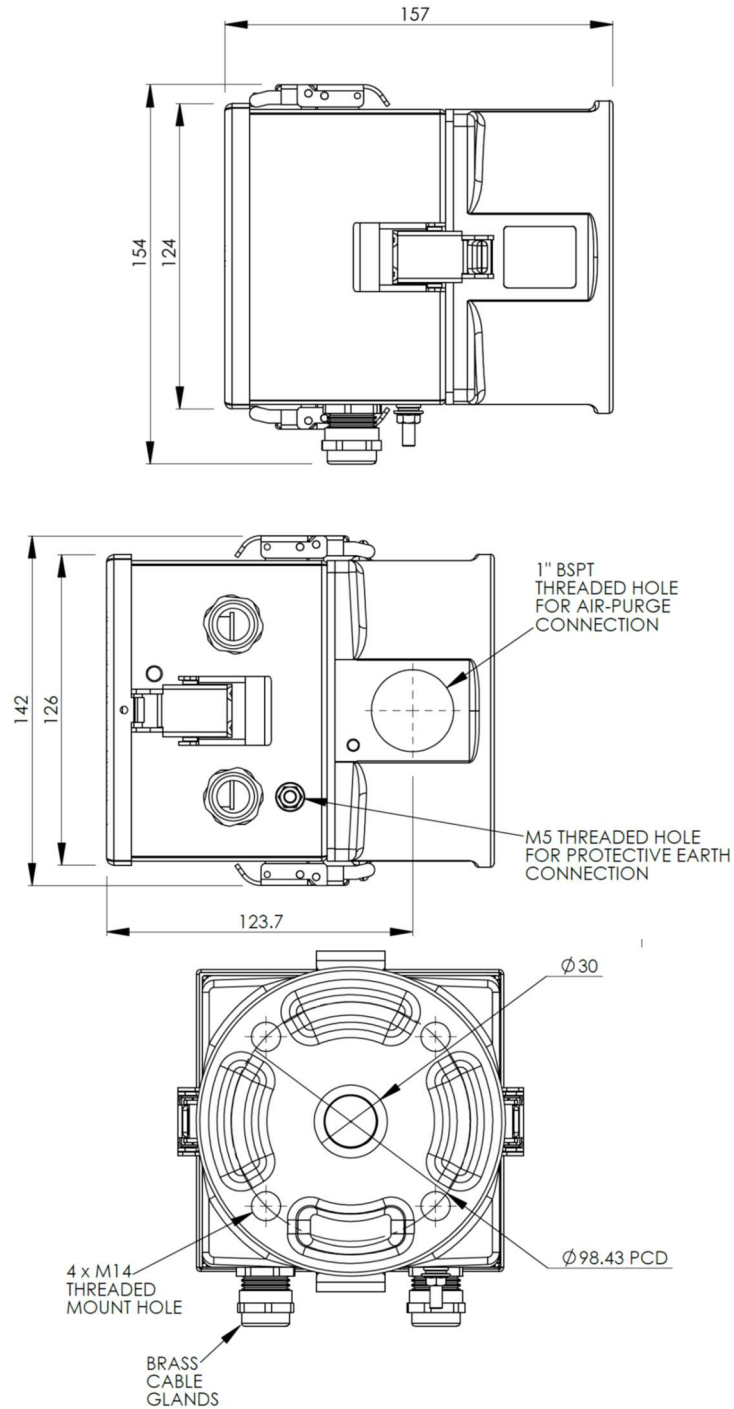



Note: The head shown is the RX head (two cable glands). The TX head (one cable gland) has exactly the same dimensions, but has one less cable gland.

sales@dynoptic.com www.dynoptic.com

Specifications are subject to change without notice.
 All images used are for illustrative purposes only. (C) 2020 Dynoptic Systems Ltd. All rights reserved.

Options & Accessories:

Description	Order Code	Notes
Mounting Flange 	ASY-067	1.5" ANSI 150 flange pattern with 240mm long extension tube (x2).
Fixing Kit	ASY-071	Contains M14 x 100mm studding, flat washers, spring washers and M14 nuts.
Weather Cover	ASY-180	Hinged stainless steel weather / heat cover for protecting externally mounted heads.
Laser Alignment Tool 	DSL-LAT08	Tool to aid the alignment of the two heads across the stack.
Blower Kit 	BK-40B-110	Blower kit for purge air. 110 Vac; single phase
	BK-40B-240	Blower kit for purge air. 240 Vac; single phase
	BK-40B-415	Blower kit for purge air. 415 Vac; three phase
Compressed Air Kit 	DSL-CAK-2	For use with compressed air purge. Includes pressure regulator, in-line filters, and compressed air adaptors for the purge bodies.

Interconnecting Cable	CBL-078	Cable for RX to TX and RX to OI. 6-core, screened pair, 20AWG. Belden equivalent 9873. Max length 300m.
	DSL-CH350A	For use between the RX head and the purge body to perform calibration checking.
	ASY-190	Calibration filter, approx 8% opacity
	ASY-133	Calibration filter, approx 20% opacity
	ASY-183	Calibration filter, approx 35% opacity

Note that the actual part may differ from the above representative pictures.